

Job Name:

System Reference:

Date:

Indoor Unit:

PVA-A12AA7

Outdoor Unit:

PUZ-A12NKA7

PUZ-A12NKA7-BS



INDOOR UNIT FEATURES

- Ducted air handler provides a solution to cool and heat large zones
- Highly efficient totally enclosed ECM motor
- Selectable external static pressure: 0.30, 0.50 and 0.80 in.WG with 3 fan speeds at each static setting
- 1 inch R4.2 fiberglass free insulation reduces condensation and boosts efficiency
- Positive pressure cabinet with air leakage of less than 1.0% at 1.0 in. w.g.
- Unique blow through design allows simple coil cleaning when the blower is removed
- Multi-position installation: horizontal (left or right), vertical (up or down). For downflow configurations, the CMA-1 is recommended for proper management of condensate to prevent water blow-off in certain conditions
- Optional electric heat kit for additional heat capacity
- Optional humidifier control and ERV control

OUTDOOR UNIT FEATURES

- Variable speed INVERTER-driven compressor
- Suction accumulator pre-charged with refrigerant volume for piping length up to 100 ft (70 ft. for A12/18/24/30)
- 24-hour continuous operation (cooling mode)
- High pressure protection
- Fast restart due to bypass valve make it ideal for equipment cooling applications, such as data centers
- Superior energy and operational efficiency

SPECIFICATIONS: PVA-A12AA7 & PUZ-A12NKA7(-BS)

Model number	Indoor unit		PVA-A12AA7
	Outdoor unit		PUZ-A12NKA7
			PUZ-A12NKA7-BS
Cooling*1	Maximum Capacity	Btu/h	12,000
	Rated Capacity	Btu/h	12,000
	Minimum Capacity	Btu/h	4,800
	Maximum Power Input	W	890
	Rated Power Input	W	890
	Moisture Removal	Pints/h	1.20
	Sensible Heat Factor		0.77
	Power factor	%	87.90
Heating at 47° F*2	Maximum Capacity	Btu/h	19,000
	Rated Capacity	Btu/h	14,000
	Minimum Capacity	Btu/h	5,700
	Maximum Power Input	W	1,730
	Rated Power Input	W	1,070
	Power factor	%	96.40
Heating at 17° F *3	Maximum Capacity	Btu/h	12,000
	Rated Capacity	Btu/h	9,900
	Maximum Power Input	W	1,440
	Rated Power Input	W	1,400
Efficiency	SEER		21.40
	EER *1		13.40
	HSPF (IV)		10.30
	COP at 47° F *2		3.83
	COP at 17° F *3		2.07
	ENERGY STAR® Certified		Yes
Electrical	Voltage, Phase, Frequency		208 / 230V, 1-phase, 60 Hz
	Guaranteed Voltage Range	V AC	187 - 253
	Voltage: Indoor - Outdoor, S1-S2	V AC	208V / 230
	Voltage: Indoor - Outdoor, S2-S3	V DC	24
	Voltage: Indoor - Remote controller	V DC	12
	Recommended Fuse/Breaker Size	A	15
	Recommended Wire Size (Indoor - Outdoor)	AWG	14
Indoor unit	MCA	A	3.00
	Fan Motor Full Load Amperage	A	2.40

SPECIFICATIONS: PVA-A12AA7 & PUZ-A12NKA7(-BS)

Model number	Indoor unit		PVA-A12AA7
	Outdoor unit		PUZ-A12NKA7
			PUZ-A12NKA7-BS
	Fan Motor Output	W	121
	Airflow Rate, Dry	CFM	280-340-400
	Airflow Rate, Wet	CFM	n/a
	External Static Pressure	in.WG	0.30-0.50-0.80
	Sound Pressure Level	dB(A)	24-28-32
	Drain Pipe Size	In. (mm)	3/4 FPT (19.05)
	Condensate Lift Mechanism, Max. Distance	In. (mm)	n/a
	Heat Exchanger Type		Plate fin coil
	External Finish Color		Galvanized steel cabinet-Powder coated Slate Gray
	Unit Dimensions // Grille Dimensions	W: In. (mm)	17 (432)
		D: In. (mm)	21-5/8 (548)
		H: In. (mm)	50-1/4 (1275)
	Unit Weight	Lbs. (kg)	51 (113)
Indoor unit operating temperature range	Cooling Intake Air Temp (Maximum / Minimum)	°F	90 DB, 73 WB / 66 DB, 59 WB
	Heating Intake Air Temp (Maximum / Minimum)	°F	82 DB / 50 DB
Outdoor unit	MCA	A	11
	MOCP	A	28
	Fan Motor Full Load Amperage	A	0.50
	Fan Motor Output	W	46
	Airflow Rate	CFM	1,590
	Refrigerant Control		Electronic Expansion Valve
	Defrost Method		Reverse Cycle
	Heat Exchanger Type		Cross fin
	Sound Pressure Level, Cooling*1	dB(A)	44
	Sound Pressure Level, Heating*2	dB(A)	46
	Compressor Type		INVERTER-driven twin rotary
	Compressor Model		SNB092FNCM
	Compressor Rated Load Amps	A	7
	Compressor Locked Rotor Amps	A	12
	Compressor Oil Type // Charge	oz.	FV50S // 12
	External Finish Color		Ivory Munsell 3Y 7.8/1.1

SPECIFICATIONS: PVA-A12AA7 & PUZ-A12NKA7(-BS)

Model number	Indoor unit		PVA-A12AA7
	Outdoor unit		PUZ-A12NKA7
			PUZ-A12NKA7-BS
	Base pan heater		n/a
	Unit Dimensions	W: In. (mm)	31-13/16 + 7/16 (809+62)
		D: In. (mm)	11-3/16 (300)
		H: In. (mm)	24-13/16 (630)
	Package Dimensions	W: In.	37-1/16
		D: In.	16-3/16
		H: In.	27-7/16
	Unit Weight	Lbs. (kg)	93 (42)
	Package Weight	Lbs. (kg)	104 (47)
Outdoor unit operating temperature range	Cooling Intake Air Temp (Maximum / Minimum)	°F	115 DB / 0* DB
	Heating Intake Air Temp (Maximum / Minimum)	°F	70 DB, 59 WB / 12 DB, 10 WB
	Thermal Lock-out / Re-start Temperatures**	°F	8 / 12 DB
Refrigerant	Type		R410A
	Charge	Lbs, oz	4 lbs, 7 oz
Piping	Gas Pipe Size O.D. (Flared)	In.(mm)	1/2 (12.7)
	Liquid Pipe Size O.D. (Flared)	In.(mm)	1/4 (6.35)
	Maximum Piping Length	Ft. (m)	100 (30)
	Maximum Height Difference	Ft. (m)	100 (30)
	Maximum Number of Bends		

AHRI Rated Conditions (Rated data is determined at a fixed compressor speed)	*1 Cooling (Indoor // Outdoor)	°F	80°F DB, 67°F WB // 95°F DB, 75°F WB
	*2 Heating at 47°F (Indoor // Outdoor)	°F	70°F DB, 60°F WB // 47°F DB, 43°F WB
	*3 Heating at 17°F (Indoor // Outdoor)	°F	70°F DB, 60°F WB // 17°F DB, 15°F WB
Conditions	*4 Heating at 5°F (Indoor // Outdoor)	°F	70°F DB, 60°F WB // -4°F DB, -5°F WB

Notes

*Wind baffles required to operate below 23°F DB in cooling mode. PUZ with wind baffle: 0°F - 115°F.

**System cuts out in heating mode to avoid thermistor error and automatically restarts at these temperatures

SPECIFICATIONS: PVA-A12AA7 & PUZ-A12NKA7(-BS)

SEACOAST PROTECTION

External Outer Panel: Phosphate coating + Acrylic-Enamel coating

Fan Motor Support: Epoxy resin coating (at edge face)

Separator Assembly; Valve Bed: Epoxy resin coating (at edge face)

“Blue Fin” treatment is an anti-corrosion treatment that is applied to the condenser coil to protect it against airborne contaminants.

Notes:

ACCESSORIES: PVA-A12AA7 & PUZ-A12NKA7(-BS)

PVA-A12AA7	
3-Pole Disconnect Switch (30A/600V/UL) [fits 2" X 4" utility box]	<input type="checkbox"/> TAZ-MS303
Drain Pan Level Sensor (Control for indoor unit shut off to prevent drain pan overflow)	<input type="checkbox"/> DPLS2
Advanced Blue Diamond Mini-Condensation pump w/ Reservoir & Sensor (110V)	<input type="checkbox"/> X87-711 - 110
Advanced Blue Diamond Mini-Condensation pump w/ Reservoir & Sensor (208/230V)	<input type="checkbox"/> X87-721 - 208/230
Extension Cord for Blue Diamond Pump	<input type="checkbox"/> C13-103
MegaBlue Blue Diamond Condensate Pump (110-230V)	<input type="checkbox"/> X87-835
Remote Sensor (extensible)	<input type="checkbox"/> PAC-SE41TS-E
Connector Cable for Remote Display	<input type="checkbox"/> PAC-SA88HA-EP
	<input type="checkbox"/> PAC-725AD-E(10pcs)
Connector for CN32 (remote on/off)	<input type="checkbox"/> PAC-SE55RA-E
Connector for CN24 (Back up heating)	<input type="checkbox"/> PAC-SE56RA-E
Connector for CN30 (LLC)	<input type="checkbox"/> PAC-SE57RA-E
Remote Operation Adapter (with wire terminals for remote ON/OFF and operation status/error)	<input type="checkbox"/> PAC-SF40RM-E ^{*1}
External fan / Heater control relay adapter	<input type="checkbox"/> CN24RELAY-KIT-CM3
Backlit, wall-mounted, wireless	<input type="checkbox"/> MHK1
Wireless adapter	<input type="checkbox"/> PAC-USWHS002-WF-1
BACnet® and Modbus Interface	<input type="checkbox"/> PAC-UKPRC001-CN-1
Wall-mounted, Wired	<input type="checkbox"/> PAC-YT53CRAU-J
Wired remote controller	<input type="checkbox"/> PAR-32MAA-J
T-STAT Interface	<input type="checkbox"/> PAC-US444CN-1 ^{*2}
Wired remote controller	<input type="checkbox"/> PAR-32MAA
Signal Receiver	<input type="checkbox"/> PAR-SA9CA-E
Wireless Remote Controller	<input type="checkbox"/> PAR-FL32MA-E
Wireless Signal Receiver	<input type="checkbox"/> PAR-FA32MA-E
Wire for Remote ON/OFF with CN32 connector	<input type="checkbox"/> PAC-715AD
Lockdown Bracket for wireless, hand-held, remote controllers	<input type="checkbox"/> RCMKP1CB

^{*1} Unable to use with wireless remote controller

^{*2} Unable to use with the electric heat time delay

PUZ-A12NKA7(-BS)	
Air Outlet Guide	<input type="checkbox"/> PAC-SJ07SG-E
Front Wind Baffle	<input type="checkbox"/> WB-PA4
Drain socket	<input type="checkbox"/> PAC-SJ08DS-E
Centralized Drain Pan	<input type="checkbox"/> PAC-SG63DP-E
M-NET Converter	<input type="checkbox"/> PAC-SJ19MA-E

ACCESSORIES: PVA-A12AA7 & PUZ-A12NKA7(-BS)

PUZ-A12NKA7(-BS)	
Control/Service Tool	<input type="checkbox"/> PAC-SK52ST
Wall mounting bracket (powder-coated steel)	<input type="checkbox"/> QCWB2000M-1
Wall mounting bracket (316 Series Stainless Steel)	<input type="checkbox"/> QCWBSS
M-NET control adapter for Building Management System	<input type="checkbox"/> PAC-SF83MA-E
Outdoor Unit Mounting Pad 16" x 36" x 3"	<input type="checkbox"/> ULTRILITE1
Outdoor Unit 3-1/4 inch Mounting Base - Pair (Plastic)	<input type="checkbox"/> DSD-400N
MiniSplit Mounting Stand-Single Fan models - 12"	<input type="checkbox"/> QSMS1201M
MiniSplit Mounting Stand-Single Fan models - 18"	<input type="checkbox"/> QSMS1801M
MiniSplit Mounting Stand-Single Fan models - 24"	<input type="checkbox"/> QSMS2401M
1/4 x 1/2 x 15' / 1/2" Lineset (Twin-Tube Insulation)	<input type="checkbox"/> MLS141212T-15
1/4 x 1/2 x 30' / 1/2" Lineset (Twin-Tube Insulation)	<input type="checkbox"/> MLS141212T-30
1/4 x 1/2 x 50' / 1/2" Lineset (Twin-Tube Insulation)	<input type="checkbox"/> MLS141212T-50
1/4 x 1/2 x 65' / 1/2" Lineset (Twin-Tube Insulation)	<input type="checkbox"/> MLS141212T-65
1/4 x 1/2 x 100' / 1/2" Lineset (Twin-Tube Insulation)	<input type="checkbox"/> MLS141212T-100

DIMENSIONS: PVA-A12AA7 & PUZ-A12NKA7 (-BS)

PVA-A12AA7

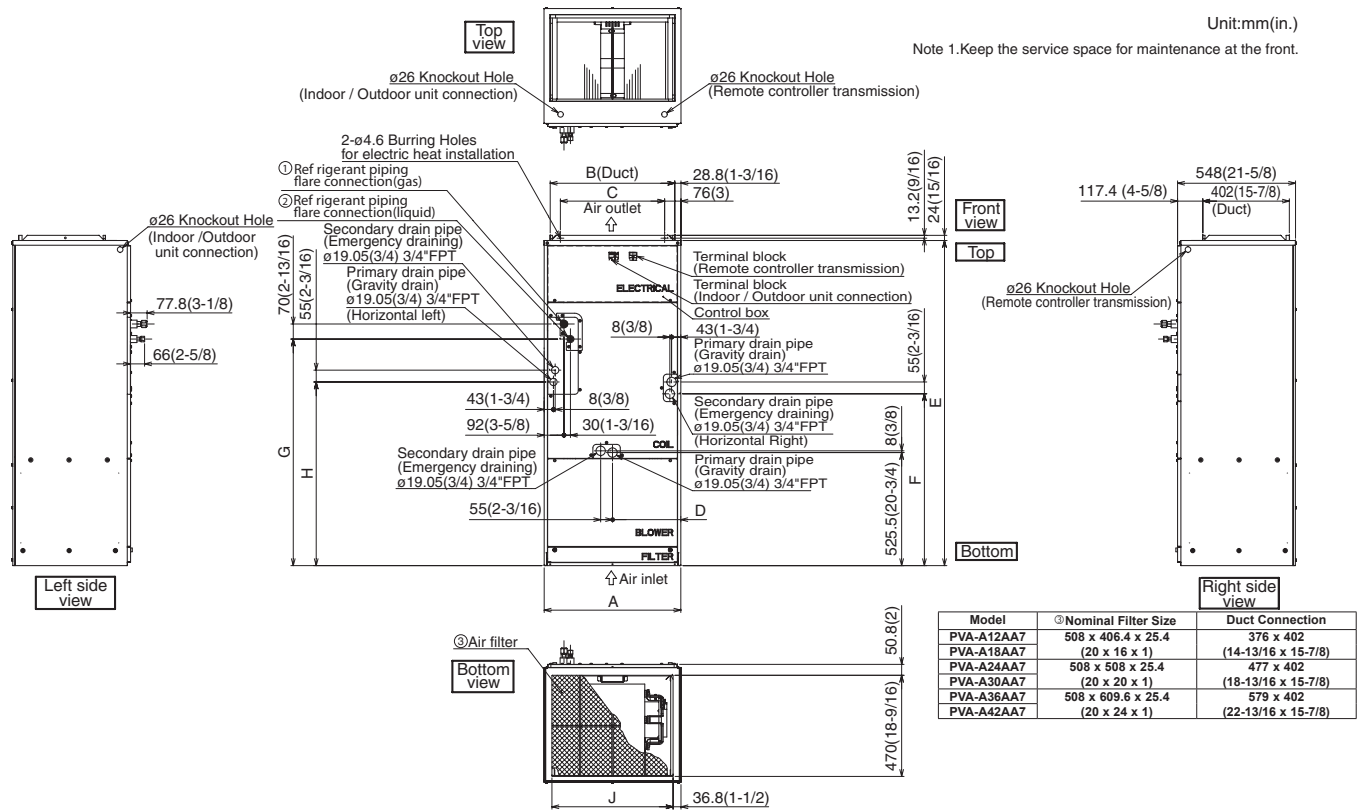

Model	A	B	C	D	E	F	G	H	J	Unit: mm (in.)	
										① Gas Pipe	② Liquid Pipe
PVA-A12AA7	432 (17)	376 (14-13/16)	281 (11-1/8)	224 (8-7/8)	1275 (50-1/4)	680 (26-13/16)	823 (32-7/16)	735.5 (29)	360 (14-3/16)	$\phi 12.7$ (1/2)	$\phi 6.35$ (1/4)
PVA-A18AA7											
PVA-A24AA7	534 (21)	477 (18-13/16)	382.6 (15-1/8)	266.5 (10-1/2)	1378 (54-1/4)	737 (29-1/16)	953.5 (37-9/16)	792 (31-3/16)	461 (18-3/16)	$\phi 15.88$ (5/8)	$\phi 9.52$ (3/8)
PVA-A30AA7											
PVA-A36AA7	635 (25)	579 (22-13/16)	484.6 (19-1/8)	317.5 (12-1/2)	1511 (59-1/2)	798.5 (31-7/16)	1053 (41-1/2)	853.5 (33-5/8)	563 (22-3/16)		
PVA-A42AA7											

DIMENSIONS: PVA-A12AA7 & PUZ-A12NKA7 (-BS)

PUZ-A12NKA7(-BS)

Unit: mm<in>

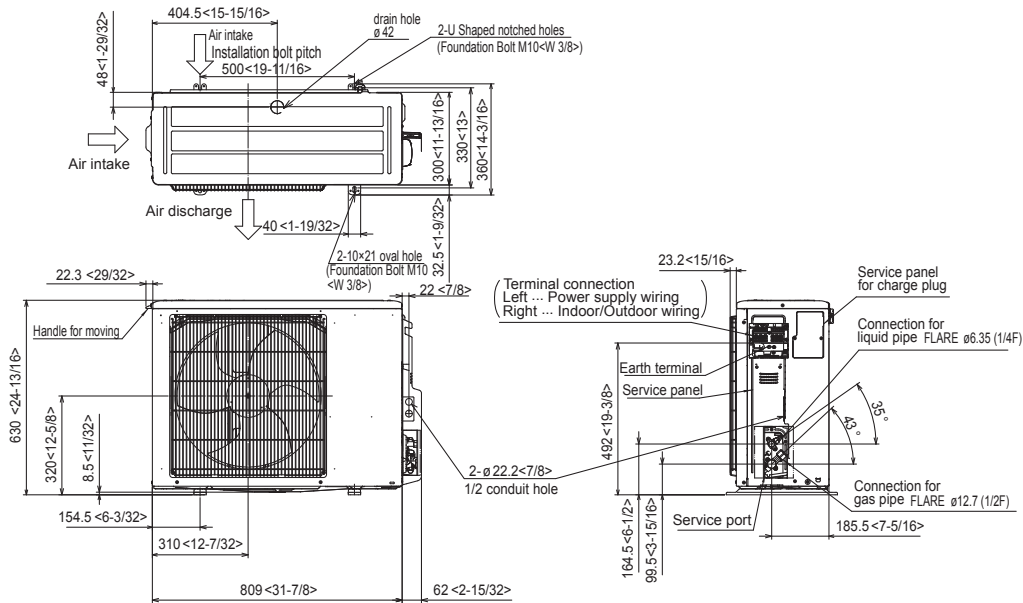

Free space around the outdoor unit (basic example)

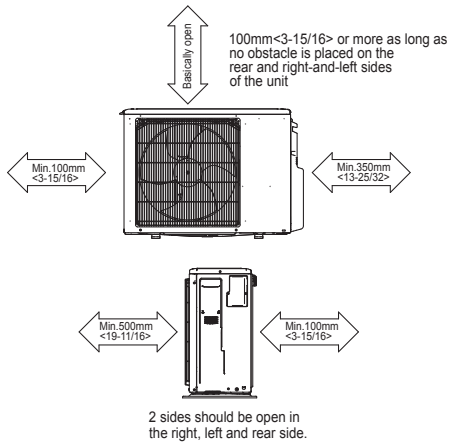

FOUNDATION BOLTS

Please secure the unit firmly with 4 foundation (M10<W3/8>) bolts. (Bolts, washers and nut must be purchased locally).

<Foundation bolt height>

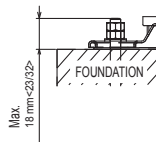

PIPING-WIRING DIRECTION

Piping and wiring connection can be made from the rear direction only.

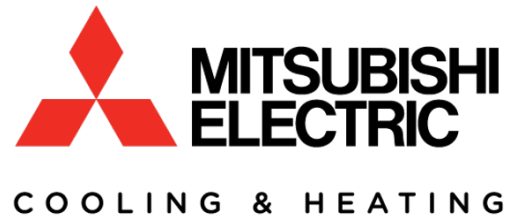

1340 Satellite Boulevard, Suwanee, GA 30024
Toll Free: 800-433-4822 www.mehvac.com

FORM# PVA-A12AA7 / PUZ-A12NKA7(-BS) - 201702Ver2

